



Standard Test Method for Transverse Compressive Properties of Hoop Wound Polymer Matrix Composite Cylinders¹

This standard is issued under the fixed designation D5449/D5449M; the number immediately following the designation indicates the year of original adoption or, in the case of revision, the year of last revision. A number in parentheses indicates the year of last reapproval. A superscript epsilon (ϵ) indicates an editorial change since the last revision or reapproval.

This standard has been approved for use by agencies of the U.S. Department of Defense.

1. Scope

1.1 This test method determines the transverse compressive properties of wound polymer matrix composites reinforced by high-modulus continuous fibers. It describes testing of hoop wound (90°) cylinders in axial compression for determination of transverse compressive properties.

1.2 The technical content of this standard has been stable since 1993 without significant objection from its stakeholders. As there is limited technical support for the maintenance of this standard, changes since that date have been limited to items required to retain consistency with other ASTM D30 Committee standards, including editorial changes and incorporation of updated guidance on specimen preconditioning and environmental testing. The standard, therefore, should not be considered to include any significant changes in approach and practice since 1993. Future maintenance of the standard will only be in response to specific requests and performed only as technical support allows.

1.3 The values stated in either SI units or inch-pound units are to be regarded separately as standard. The values stated in each system are not exact equivalents; therefore, each system must be used independently of the other. Combining values from the two systems may result in nonconformance with the standard.

1.3.1 Within the text the inch-pound units are shown in brackets.

1.4 *This standard does not purport to address all of the safety concerns, if any, associated with its use. It is the responsibility of the user of this standard to establish appropriate safety and health practices and determine the applicability of regulatory limitations prior to use.*

¹ This test method is under the jurisdiction of ASTM Committee D30 on Composite Materials and is the direct responsibility of Subcommittee D30.04 on Lamina and Laminate Test Methods.

Current edition approved July 1, 2016. Published July 2016. Originally approved in 1993. Last previous edition approved in 2011 as D5449/D5449M – 11. DOI: 10.1520/D5449_D5449M-16.

2. Referenced Documents

2.1 ASTM Standards:²

- D792 Test Methods for Density and Specific Gravity (Relative Density) of Plastics by Displacement
- D883 Terminology Relating to Plastics
- D2584 Test Method for Ignition Loss of Cured Reinforced Resins
- D2734 Test Methods for Void Content of Reinforced Plastics
- D3171 Test Methods for Constituent Content of Composite Materials
- D3878 Terminology for Composite Materials
- D5229/D5229M Test Method for Moisture Absorption Properties and Equilibrium Conditioning of Polymer Matrix Composite Materials
- D5448/D5448M Test Method for Inplane Shear Properties of Hoop Wound Polymer Matrix Composite Cylinders
- D5450/D5450M Test Method for Transverse Tensile Properties of Hoop Wound Polymer Matrix Composite Cylinders
- E4 Practices for Force Verification of Testing Machines
- E6 Terminology Relating to Methods of Mechanical Testing
- E11 Specification for Woven Wire Test Sieve Cloth and Test Sieves
- E122 Practice for Calculating Sample Size to Estimate, With Specified Precision, the Average for a Characteristic of a Lot or Process
- E132 Test Method for Poisson's Ratio at Room Temperature
- E177 Practice for Use of the Terms Precision and Bias in ASTM Test Methods
- E251 Test Methods for Performance Characteristics of Metallic Bonded Resistance Strain Gages
- E456 Terminology Relating to Quality and Statistics
- E691 Practice for Conducting an Interlaboratory Study to Determine the Precision of a Test Method
- E1237 Guide for Installing Bonded Resistance Strain Gages

² For referenced ASTM standards, visit the ASTM website, www.astm.org, or contact ASTM Customer Service at service@astm.org. For *Annual Book of ASTM Standards* volume information, refer to the standard's Document Summary page on the ASTM website.

3. Terminology

3.1 *Definitions*—Terminology **D3878** defines terms relating to high-modulus fibers and their composites. Terminology **D883** defines terms relating to plastics. Terminology **E6** defines terms relating to mechanical testing. Terminology **E456** and Practice **E177** defines terms relating to statistics. In the event of a conflict between terms, Terminology **D3878** shall have precedence over other standards.

NOTE 1—If the term represents a physical quantity, its analytical dimensions are stated immediately following the term (or letter symbol) in fundamental dimension form, using the following ASTM standard symbology for fundamental dimensions, shown within square brackets: [M] for mass, [L] for length, [T] for time, [θ] for thermodynamic temperature, and [nd] for non-dimensional quantities. Use of these symbols is restricted to analytical dimensions when used with square brackets, as the symbols may have other definitions when used without the brackets.

3.2 *Definitions of Terms Specific to This Standard:*³

3.2.1 *winding*—an entire part completed by one winding operation and then cured.

3.2.2 *hoop wound, n*—a winding of a cylindrical component in which the filaments are circumferentially oriented.

3.2.3 *specimen*—a single part cut from a winding. Each winding may yield several specimens.

3.2.4 *transverse compressive modulus, E_{22} [$ML^{-1}T^{-2}$], n* —the compressive elastic modulus of a unidirectional material in the direction perpendicular to the reinforcing fibers.

3.2.5 *transverse compressive strength, σ_{22}^{uc} , [$ML^{-1}T^{-2}$], n* —the strength of a unidirectional material when a compressive force is applied in the direction perpendicular to the reinforcing fibers.

3.2.6 *transverse compressive strain at failure, ϵ_{22}^{uc} [nd], n* —the value of strain, perpendicular to the reinforcing fibers in a unidirectional material, at failure when a compressive force is applied in the direction perpendicular to the reinforcing fibers.

4. Summary of Test Method

4.1 A thin-walled hoop wound cylinder nominally 100 mm [4 in.] in diameter and 140 mm [5½ in.] in length is bonded into two end fixtures. The specimen fixture assembly is mounted in the testing machine and monotonically loaded in compression while recording force. The transverse compressive strength can be determined from the maximum force carried before failure. If the cylinder strain is monitored with strain gauges then the stress-strain response, the compressive strain at failure, transverse compression modulus of elasticity, and Poisson's ratio can be derived.

5. Significance and Use

5.1 This test method is designed to produce transverse compressive property data for material specifications, research

³ If the term represents a physical quantity, its analytical dimensions are stated immediately following the term (or letter symbol) in fundamental dimension form, using the following ASTM standard symbology for fundamental dimensions, shown within square brackets: [M] for mass, [L] for length, [T] for time, [θ] for thermodynamic temperature, and [nd] for nondimensional quantities. Use of these symbols is restricted to analytical dimensions when used with square brackets, as the symbols may have other definitions when used without the brackets.

and development, quality assurance, and structural design and analysis. Factors that influence the transverse compressive response and should therefore be reported are: material, method of material preparation, specimen preparation, specimen conditioning, environment of testing, specimen alignment and gripping, speed of testing, void content, and fiber volume fraction. Properties in the test direction that may be obtained from this test method are:

5.1.1 Transverse compressive strength, σ_{22}^{uc} ,

5.1.2 Transverse compressive strain at failure, ϵ_{22}^{uc} ,

5.1.3 Transverse compressive modulus of elasticity, E_{22} , and

5.1.4 Poisson's ratio, γ_{21} .

6. Interference

6.1 *Material and Specimen Preparation*—Poor material fabrication practices, lack of control of fiber alignment, and damage induced by improper specimen machining are known causes of high material data scatter in composites.

6.2 *Bonding Specimens to Test Fixtures*—A high percentage of failures in or near the bond between the test specimen and the test fixture, especially when combined with high material data scatter, is an indicator of specimen bonding problems. Specimen to fixture bonding is discussed in **11.5**.

6.3 *System Alignment*—Excessive bending may cause premature failure, as well as highly inaccurate modulus of elasticity determination. Every effort should be made to eliminate excess bending from the test system. Bending may occur as a result of misaligned grips, misaligned specimens in the test fixtures, or from departures of the specimens from tolerance requirements. The alignment should always be checked as discussed in **13.2**.

7. Apparatus

7.1 *Micrometers and Calipers*—A micrometer with a 4 to 7 mm [0.16 to 0.28 in.] nominal diameter ball-interface or a flat anvil interface shall be used to measure the specimen wall thickness, inner diameter, and outer diameter. A ball interface is recommended for these measurements when at least one surface is irregular (e.g. a course peel ply surface, which is neither smooth nor flat). A micrometer or caliper with a flat anvil interface shall be used for measuring the overall specimen length, the gauge length (the free length between the fixtures) and other machined surface dimensions. The use of alternative measurement devices is permitted if specified (or agreed to) by the test requestor and reported by the testing laboratory. The accuracy of the instruments shall be suitable for reading to within 1 % of the sample dimensions. For typical specimen geometries, an instrument with an accuracy of ± 0.0025 mm [± 0.0001 in.] is adequate for wall thickness measurements, while an instrument with an accuracy of ± 0.025 mm [± 0.001 in.] is adequate for measurement of the inner diameter, outer diameter, overall specimen length, gauge length, and other machined surface dimensions.

7.2 *Compression Fixture*—The compression fixture consists of a steel outer shell and insert. An assembly drawing for these components and the test fixture is shown in **Fig. 1**.

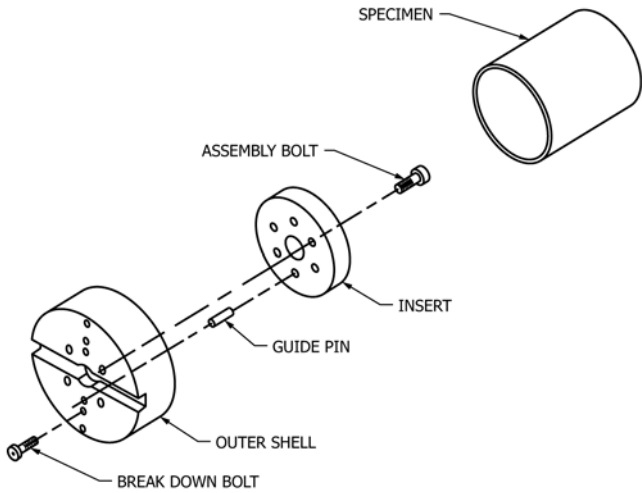

FIG. 1 Assembly Drawing for the Compression Fixture and Specimen

7.2.1 *Outer Shell*—The outer shell (SI units Fig. 2, English units Fig. 3) is circular with a concentric circular hollow in one face, a groove along the diameter of the other face, and a center hole through the thickness. Along the diameter perpendicular to the groove, three pairs of small eccentric holes are placed at three radial distances. The two outer pairs of holes are threaded. Four additional threaded holes are placed at the same radial distance as the innermost pair of holes at 90° intervals starting 45° from the diameter that passes through the center groove.

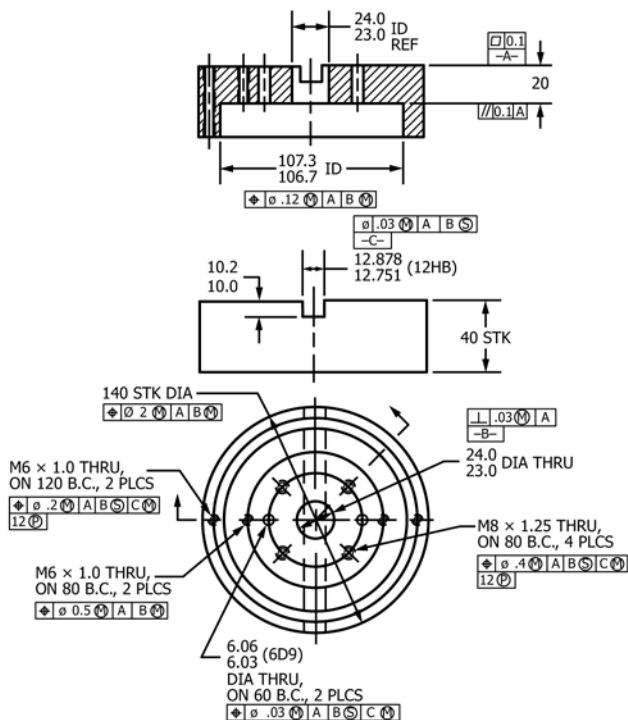

FIG. 2 The Outer Shell of the Compression Fixture in Metric Units

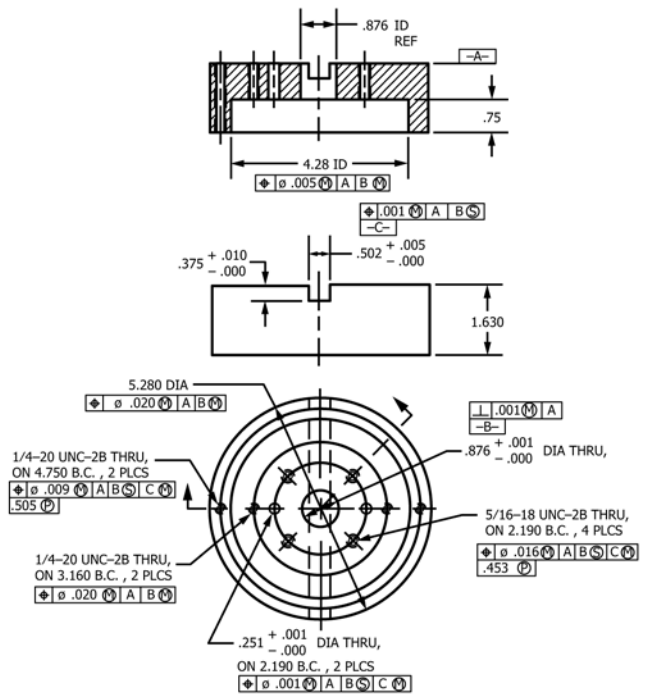

FIG. 3 The Outer Shell of the Compression Fixture in English Units

7.2.2 *Insert*—The fixture insert is circular with a center hole through the thickness (SI units Fig. 4, English units Fig. 5). Two sets of holes are placed along a concentric centerline. These holes align with the innermost set of holes in the outer shell. The set of four holes at 90° intervals are counterbored.

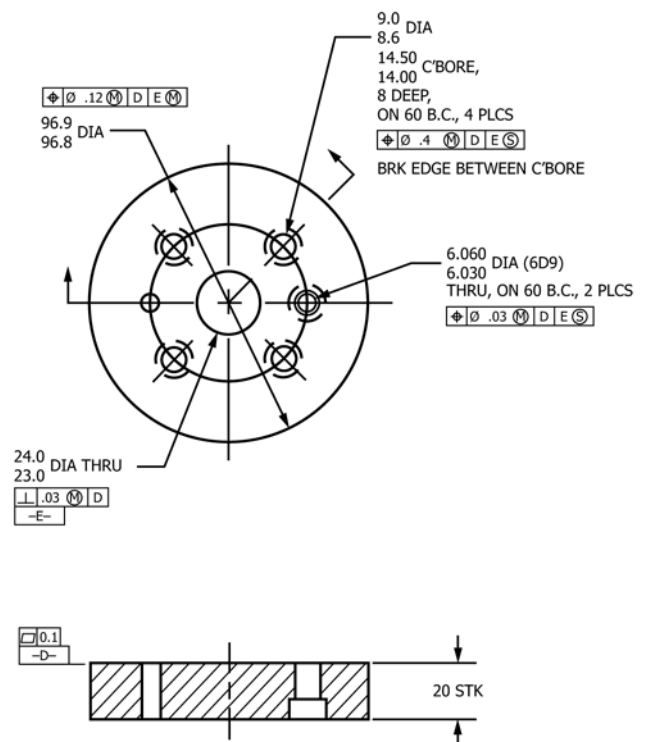

FIG. 4 The Insert of the Compression Fixture in Metric Units